

DA Series

PCB mount ultra compact, regulated, high voltage DC-DC converter



- 72 standard products
- Reference: see chart for complete reference
- Vin: 15Vdc or 24Vdc
- Vout: 0 to 1kV, 2kV or 4kV
- Pout: 1W, 2W or 4W



General Description

The DA Series is particularly adapted to controlling photonic detectors that need high bias voltages and currents. Industrials, integrators and researchers will benefit from the units small size, lightweight design, excellent voltage regulation and reduced residual undulation.

Small height and lightweight	Tight line / load regulation	Low ripple (0.005% p. to p.)
PCB flat mounting	Output current limit protection	Low noise due to metal shielding
Adjustable from 0 to full output	Low ripple (<0,003% p. to p.)	Voltage and current buffered monitoring

Parameters	Specifications
Input voltage Vin (pins 2 & 3)	15Vdc \pm 1.5Vdc or 24Vdc \pm 2Vdc, according to type
Input current	Example for a 15Vdc, output 6000V,1mA model: inhibition mode: 27mA at no load & HV=1500V: 46mA at full load: 260mA
HV output Vout (pin 8)	0 to 1000V through 0 to 4000V according to type
Polarity	Fixed positive [DAP] or negative [DAN]; refer to the Selection Guide
HV setting (pins 4 & 6)	<ul style="list-style-type: none"> • Option 1: via external voltage source 0/ 5V \pm0.1 % at full scale, and input impedance = 94kΩ • Option 2: via external voltage source 0/10V \pm0.1 % at full scale, and input impedance = 187kΩ
Max. output current Iout	Limited to 110 % of nominal current; refer to the Selection Guide
Load voltage regulation	\pm 0,01 % of full output voltage for no load to full load
Line voltage regulation	\pm 0,01 % of full output voltage over specified input voltage range
Residual ripple	0,005 % peak-to-peak at full load
Temperature coefficient	100ppm/ $^{\circ}$ C
Output HV monitoring (pin 7) (still operating in inhibition mode)	<ul style="list-style-type: none"> • Option 1: analog 0/+ 5V buffered output signal, accuracy \pm0.2 % • Option 2: analog 0/+10V buffered output signal, accuracy \pm0.2 % Output impedance = 1k Ω Temperature coefficient: 100ppm/ $^{\circ}$ C

DA Series

PCB mount ultra compact, regulated, high voltage DC-DC converter

Parameters	Specifications
Output current monitoring (pin 5) (still operating in inhibition mode)	<ul style="list-style-type: none">• Option1: analog 0/+ 5V buffered output signal, accuracy $\pm 2\%$• Option2: analog 0/+10V buffered output signal, accuracy $\pm 2\%$ Output impedance = 1k Ω Temperature coefficient : 100ppm/ $^{\circ}\text{C}$
HV power ON/OFF	To disable (opened remote interlock) or enable (closed remote interlock)
Operating temperature	Refer to Derating Curve
Storage temperature	-10 $^{\circ}\text{C}$ to +70 $^{\circ}\text{C}$
Safeguards	<ul style="list-style-type: none">• Protected against reverse Vin• Soft start feature : the start is guaranteed with no overshoot• Auto inhibition if Tcase > 75$^{\circ}\text{C}$• HV setting internally limited to 10.6V for the 10V version and to 5.3V for the 5V version

Main Applications

- Avalanche Photo Diodes (APD)
- Electrostatic Chuck (E-chuck)
- Gas Chromatography
- Geiger-Müller Tubes (GM Tubes)
- Particle physics detectors
- Scanning electron microscopes
- Laser range finder detectors
- Photomultiplier Tubes (PMT)
- PZT Drivers

Package Configuration

Case material	Tin steel plate Thickness 0.5 mm
Case dimensions LxHxW	63.5 x 13.0 x 44.0 mm
Pins	0.63 x 0.63 mm square pins, Length : > 6 mm, Spacing: 2.54 mm
Weight	72 g
Insulation	Fully potted in an epoxy resin

Pin Connections

Inhibition input	1. ON/OFF
Line input	2. 0V supply 3. Vin
HV setting	3. 0V signal 4. Control input
HV monitoring	5. Current monitoring 6. Voltage monitoring
HV output	7. Vout



DA Series

PCB mount ultra compact, regulated, high voltage DC-DC converter

Marking

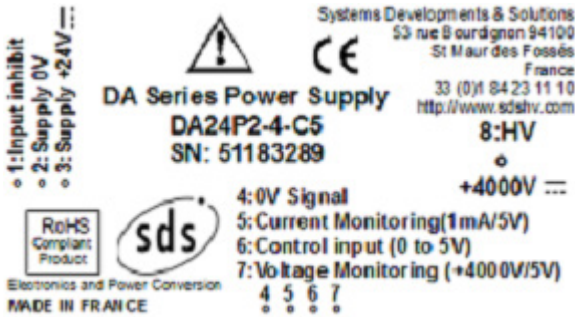

Derating Curve

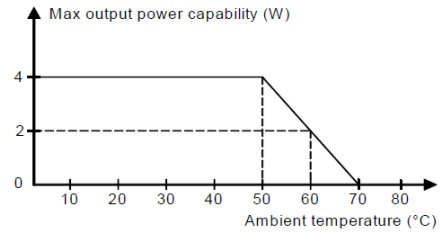

Under certain environmental conditions, and for some configurations, the installation of a heatsink might be necessary

Mechanical dimensions

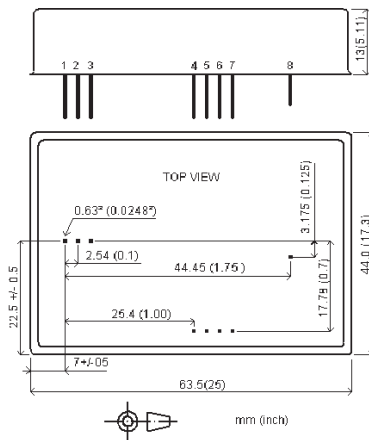

Functional diagram

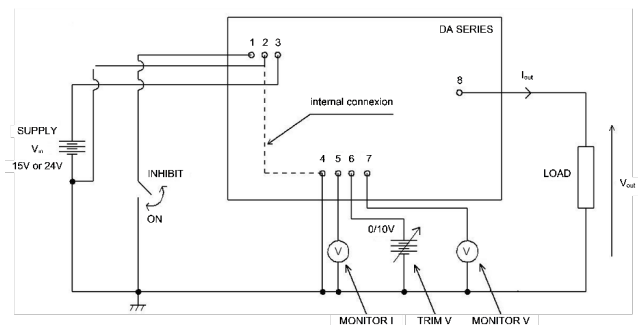

DA Series

PCB mount ultra compact, regulated, high voltage DC-DC converter

Ordering information

Model	Name of the series	DA
Vin	15Vdc nominal	12
	24Vdc nominal	24
Polarity	Positive output voltage	P
	Negative output voltage	N
Vout	Output voltage	See ordering code
Pout	Output in Watt	See ordering code
Output HV Monitoring	+5Vdc control reference voltage	C5
	+10Vdc control reference voltage	C10

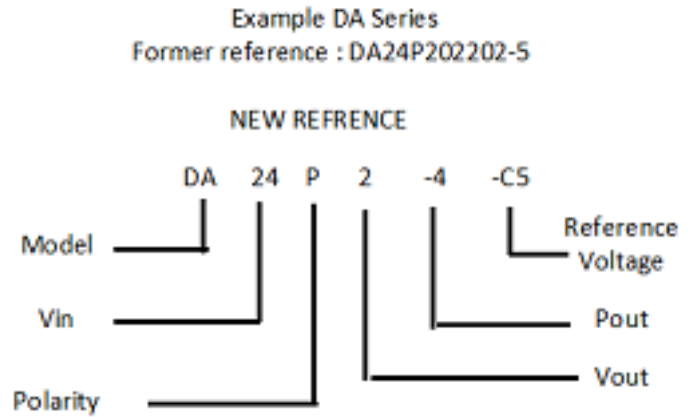

Ordering voltage and power code

- The power supplies have a 6-element order code:
 - The first 2 letters refer to the series
 - The first 2 digits indicate the value of the input voltage
 - the following letter indicates the polarity
 - the following number indicates the output voltage in kV
 - the last digit indicates the power in Watt
 - the last digit preceded by the letter «C» refers to the output HV monitoring

Ordering example

The ordering code of a +2kV@4W psu under 24Vdc and with 0/5V controls is: DA24P2-4-C5

DA Series overview

		Pout (W)		
		1	2	4
Vout (Vdc)	1000	DAxx1-1-C	DAxx1-2-C	DAxx1-4-C
	2000	DAxx1-1-C	DAxx1-2-C	DAxx1-4-C
	4000	DAxx1-1-C	DAxx1-2-C	DAxx1-4-C

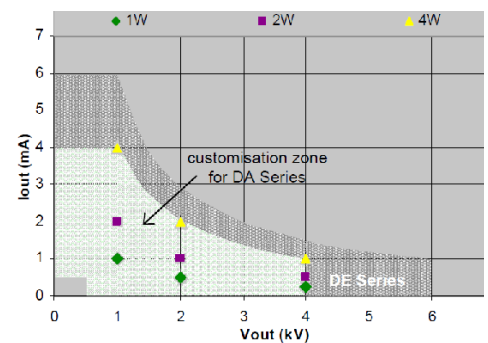

xx: input voltage
4kV@2W and 4kV@4W are available only under 24Vdc

Other output voltages and output currents are available upon request.

Do not hesitate to ask us about any parameter you would like to see changed for your application.



DA Series

PCB mount ultra compact, regulated, high voltage DC-DC converter

DA Series selection guide

Vout	Iout/Pout	Vin	Polarity	HV monitoring	former refrence	NEW REFERENCE	
4000V	1.00mA/4W	24V	+	0/10V	DA24P402102-10	DA24P4-4-C10	
				0/5V	DA24P402102-5	DA24P4-4-C5	
			-	0/10V	DA24N402102-10	DA24N4-4-C10	
				0/5V	DA24N402102-5	DA24N4-4-C5	
	0.50mA/2W	24V	+	0/10V	DA24P402501-10	DA24P4-2-C10	
				0/5V	DA24P402501-5	DA24P4-2-C5	
			-	0/10V	DA24N402501-10	DA24N4-2-C10	
				0/5V	DA24N402501-5	DA24N4-2-C5	
	0.25mA/1W	15V	+	0/10V	DA15P402251-10	DA15P4-1-C10	
				0/5V	DA15P402251-5	DA15P4-1-C5	
			-	0/10V	DA15N402251-10	DA15N4-1-C10	
				0/5V	DA15N402251-5	DA15N4-1-C5	
24V		+	0/10V	DAP24402251-10	DA24P4-1-C10		
			0/5V	DAP24402251-5	DA24P4-1-C5		
		-	0/10V	DAN24402251-10	DA24N4-1-C10		
			0/5V	DAN24402251-10	DA24N4-1-C5		
2000V	2.00mA/4W	15V	+	0/10V	DA15P202202-10	DA15P2-4-C10	
				0/5V	DA15P202202-5	DA15P2-4-C5	
			-	0/10V	DA15N202202-10	DA15N2-4-C10	
				0/5V	DA15N202202-5	DA15N2-4-C5	
		24V	+	0/10V	DA24P202202-10	DA24P2-4-C10	
				0/5V	DA24P202202-5	DA24P2-4-C5	
			-	0/10V	DA24N202202-10	DA24N2-4-C10	
				0/5V	DA24N202202-5	DA24N2-4-C5	
	1.00mA/2W	15V	+	0/10V	DA15P202102-10	DA15P2-2-C10	
				0/5V	DA15P202102-5	DA15P2-2-C5	
			-	0/10V	DA15N202102-10	DA15N2-2-C10	
				0/5V	DA15N202102-5	DA15N2-2-C5	
		24V	+	0/10V	DA24P201102-10	DA24P2-2-C10	
				0/5V	DA24P201102-5	DA24P2-2-C5	
			-	0/10V	DA24N201102-10	DA24N2-2-C10	
				0/5V	DA24N201102-5	DA24N2-2-C5	
	0.50mA/1W	15V	+	0/10V	DA15P202501-10	DA15P2-1-C10	
				0/5V	DA15P202501-5	DA15P2-1-C5	
			-	0/10V	DA15N202501-10	DA15N2-1-C10	
				0/5V	DA15N202501-5	DA15N2-1-C5	
			24V	+	0/10V	DA24P202501-10	DA24P2-1-C10
					0/5V	DA24P202501-5	DA24P2-1-C5
		-		0/10V	DA24N202501-10	DA24N2-1-C10	
				0/5V	DA24N202501-5	DA24N2-1-C5	

DA Series

PCB mount ultra compact, regulated, high voltage DC-DC converter

DA Series selection guide (continued)

Vout	Iout/Pout	Vin	Polarity	Ctrl. Monitor		Model
1000V	4.00mA/4W	15V	+	0/10V	DA15P102402-10	DA15P1-4-C10
				0/5V	DA15P102402-5	DA15P1-4-C5
		15V	-	0/10V	DA15N102402-10	DA15N1-4-C10
				0/5V	DA15N102402-5	DA15N1-4-C5
		24V	+	0/10V	DA24P102402-10	DA24P1-4-C10
				0/5V	DA24P102402-5	DA24P1-4-C5
	24V	-	0/10V	DA24N102402-10	DA24N1-4-C10	
			0/5V	DA24N102402-5	DA24N1-4-C5	
	2.00mA/2W	15V	+	0/10V	DA15P102202-10	DA15P1-2-C10
				0/5V	DA15P102202-5	DA15P1-2-C5
		15V	-	0/10V	DA15N102202-10	DA15N1-2-C10
				0/5V	DA15N102202-5	DA15N1-2-C5
		24V	+	0/10V	DA24P102202-10	DA24P1-2-C10
				0/5V	DA24P102202-5	DA24P1-2-C5
	24V	-	0/10V	DA24N102202-10	DA24N1-2-C10	
			0/5V	DA24N102202-5	DA24N1-2-C5	
	1mA/1W	15V	+	0/10V	DA15P102102-10	DA15P1-1-C10
				0/5V	DA15P102102-5	DA15P1-1-C5
		15V	-	0/10V	DA15N102102-10	DA15N1-1-C10
				0/5V	DA15N102102-5	DA15N1-1-C5
		24V	+	0/10V	DA24P102102-10	DA24P1-1-C10
				0/5V	DA24P102102-5	DA24P1-1-C5
	24V	-	0/10V	DA24N102102-10	DA24N1-1-C10	
			0/5V	DA24N102102-5	DA24N1-1-C5	

Do not hesitate to ask us about any parameter you would like to see changed for your application.



This High Voltage power supply satisfies the requirements of EC Directives Safety.

Non contractual document.
All specifications are subject to change without notice.

Rev.C 06/16

